

PSC-BL-I-RT-DC0-BLE-SR | Bi-level Dimming PIR Sensor

Overview

- Dual Element PIR sensor
- 0-10V configurable output: set to 0% (OFF)*, 10%, 25% or 50% dimming
- Photocell for ambient light detection
- Time delay 1 adjustable 5 sec to 30 min
- Time delay 2 adjustable 10 sec to ∞
- LED Motion indicator
- Active High/Low outputs for Relay drive
- Mounting height of 10ft (3m).
- 360° coverage pattern
- Bluetooth add-on enables remote sensor programming with greater customization of dimming levels, time delays, and ambient light sensitivity



Suitable for indoor use only



Suffix “-BLE-FSR” is also in compliance with IC, AS/NZS and JAPAN for Radio Communication

Applications

The ATG Wireless Control System PSC-BL-I-RT-DC0 provided by McWong uses digital PIR Motion Detector Architecture and Dual Element passive infrared (PIR) technology for improved detection coverage for ceiling mount, high bay, and low bay applications.

The PSC-BL-I-RT-DC0 is a Class 2 Device designed to satisfy new CA Title 24 requirements for bi-level dimming of lighting fixtures. Using a 0-10V signal, the sensor is capable of dimming lighting loads down to 0%*, 10%, 25%, or 50%.

The sensor is suitable for a variety of applications. It supports fixture and ceiling mounts up to 10ft (3m) high. Both sensor and power pack are rated for use in temperatures ranging from -30° to 70°C and relative humidity from 90 to 95% at 30°C.

0-10V: 100mA to drive up to 50 LED sink drivers on 0-10V output.
High Vin-2.5V 100mA source
Low 100mA sink current

*For dim to off, Pacific PSC-AC-PP-200 Power Pack or LED dimming driver capable of dimming to off is required.

Sensor Operation

End users can program length of time delays, light level sensitivity, sensor range and other settings using a series of dipswitches and trim pots.

Bi-level Dimming:** 0-10V bi-level dimmer connects to 0-10V control on the LED driver. When motion is detected the sensor will bring lighting up to 100% lumen output. When no motion is detected for the length of TD1, the sensor will send a signal to dim lighting to a specific level set by the end-user. If no motion is detected for the length of TD2, the sensor will send a signal to shut off the light.

Relay Control: Two additional High and Low control outputs can be used to trigger relays or other control circuitry.

Bluetooth smart and Bluetooth mesh: The Bluetooth Low Energy (BLE) enabled version pairs with an Android or iOS application to allow initial setup and subsequent sensor adjustments, beyond what the analog controls on the sensor can offer. The mobile application enables adjustment of sensor parameters such as time delay, dim level, sensitivity, ambient light level, and more. Additionally, features such as parameter profiles, manual dim control, and real-time feedback from the sensor can speed up configuration and provide custom user control. The Bluetooth Smart™ enabled sensors support mesh networking through a variety of software and wireless platforms.

Accessories

Power Pack: The PSC-BL-I-RT-DC0 operates on 12-24VDC input and requires a separate power pack such as the PacWave™ PSC-AC-PP-200/400/700C.

This power pack incorporates a high current relay and a high voltage transformer which can accept universal input (100-305VAC).

Alternatively, the sensor can also operate with a driver that has an auxiliary output (12V).

Carclo Lens:
WAL: 10ft Carclo Wide angle lens

**The sensor will dim the light if motion is not detected for the first time delay (TD1) and shut off the light if motion is not detected for the second time delay (TD2). TD2 will only count down after TD1 has expired and the light has dimmed. If motion is detected during TD2, the light will return to full output, and TD1 will restart.

If using a power pack, the sensor will tell the power pack to shut off the driver after TD2 expires to turn off the light. If using a dimming driver without a power pack, the sensor will try to dim down to 0% upon expiration of TD2.

Since one trim pot configures both TD1 and TD2, a fixed TD2 is set to each value of TD1. See page 2 for the corresponding values.

How to Order

Model No.	Description	Input Voltage	Output
PSC-BL-I-RT-DC0-BLE-SR	Bi-Level Passive Infrared (PIR) Remote Mount Occupancy Sensor	12-24VDC	0-10VDC Control High Control Low
PSC-AC-PP-200	Dimming Power Pack for Fixture Mount	100-277VAC	12.5VDC
PSC-AC-PP-400	Power Pack for Fixture Mount no Relay	100-277VAC	12.5VDC
Add Suffix for options:			
/C	with Connector, see page 4, Lead Option B		

Summary	
Sensor Type	PIR occupancy sensor
Input Voltage Current Consumption	12-24VDC 25mA sensor (50mA w/ BLE)
0-10V Output	100mA, up to 50LED sink drivers
High	Vin-2.5V 100mA source
Low	100mA sink current
Mounting Height	Fixture or ceiling mount at 10ft (3m)
Max Range*	10ft (3m) radius
Time Delays (TD1/TD2)**	5 sec/10 sec, 5 min/30 min, 15 min/45 min, 30 min/60 min, 10 min/∞****
Photocell Sensitivity**	30 Lux to daylight
Max Bluetooth Range***	49 ~ 65ft (15 ~ 20m)
Operating Temperature	-30° C to 70°C
Storage Temperature	-40° C to 80°C
Relative Humidity	90-95% non-condensing at 30°C
Color	White
Warranty	5 years

Note:
 *The absolute range of the sensor is subject to variation because of different types of clothing, backgrounds, and ambient temperature. Therefore, ensure that the lens is properly oriented along routes with expected traffic and conduct testing along those routes.
 **Bluetooth versions enable adjustment of sensor parameters such as time delay, dim level, sensitivity, photocell sensitivity, and more.
 ***Bluetooth Range is highly dependent on the integration of fixtures, surrounding environment and conditions. It is recommended to conduct testing for range accuracy.
 ****If TD1 is set to 10 min, TD2 will never expire. So the light will remain at the dim level for as long as motion is not detected.

Settings Adjustment



Dipswitch 1	Dipswitch 2	DIM Level
OFF	OFF	OFF
OFF	ON	10%
ON	OFF	25%
ON	ON	50%

Trim pots

Trimpot #1 on left adjusts time delay. Trimpot #2 in middle adjusts ambient light sensitivity. Trimpot #3 on right adjusts motion detection range and sensitivity. Turn clockwise to increase, turn counterclockwise to decrease.

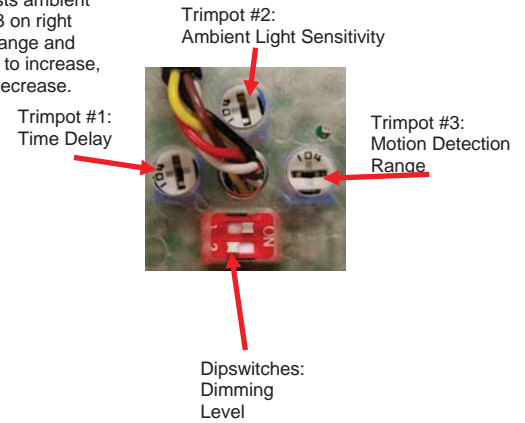

Wiring Diagram

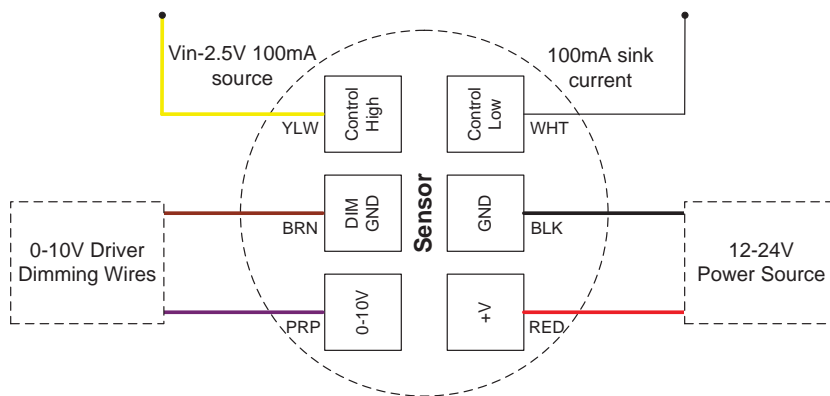

Note: If using a power pack other than PSC-AC-PP-200, connect either Control Hi or Control Low, depending on power pack relay circuitry.

*** If TD1 is set to 10 min, TD2 will never expire. So the light will remain at the dim level for as long as motion is not detected.

Physical Dimensions

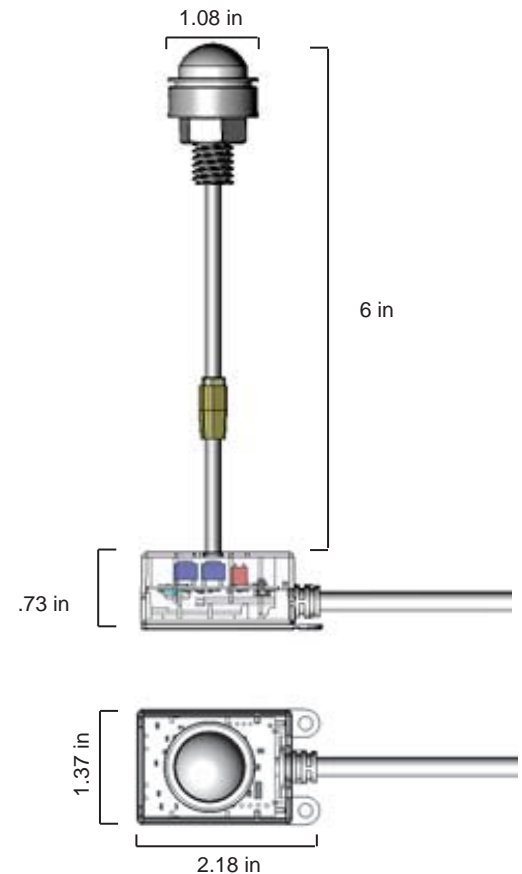

Detection Area

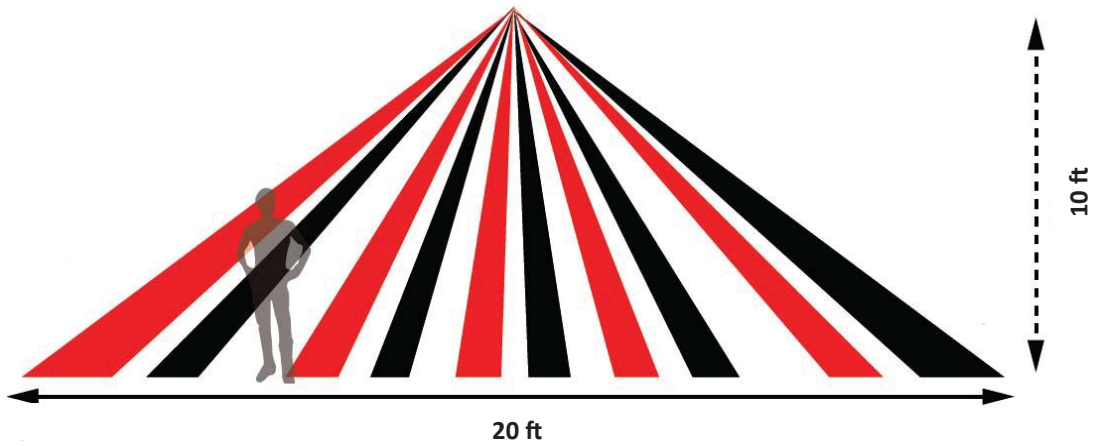

Installation

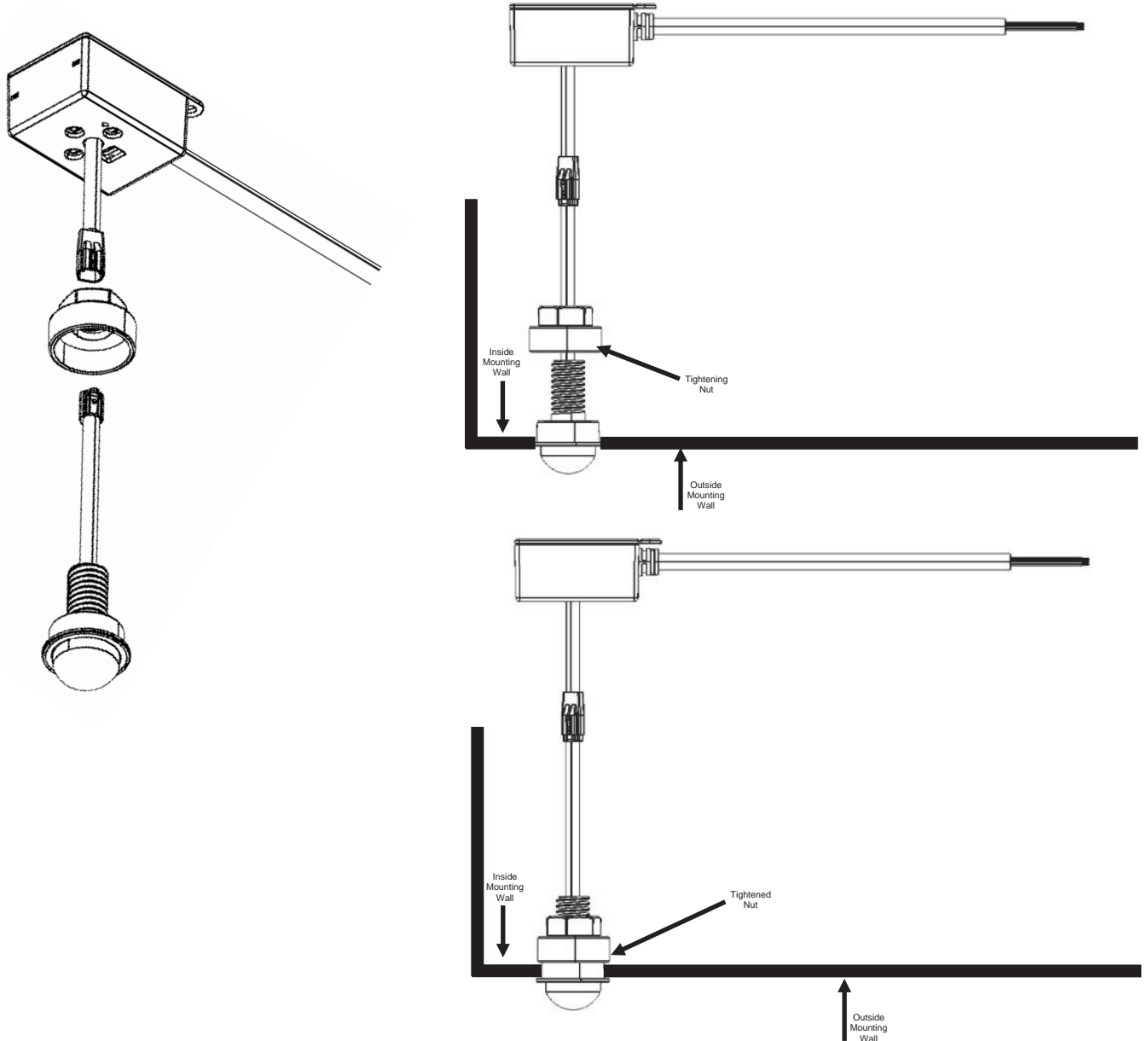

Lead Options:

Option A (Standard):

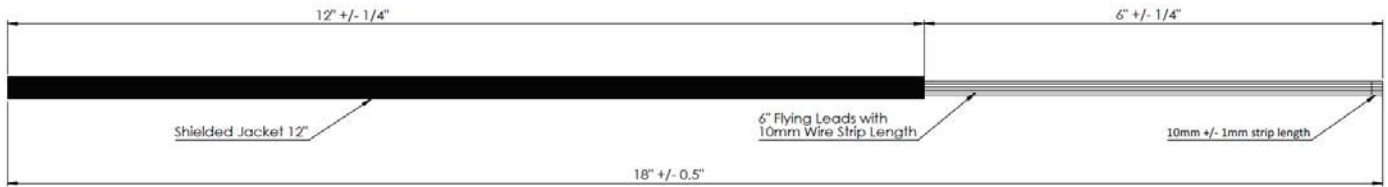

Option B (/C):

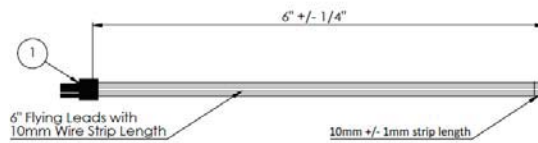
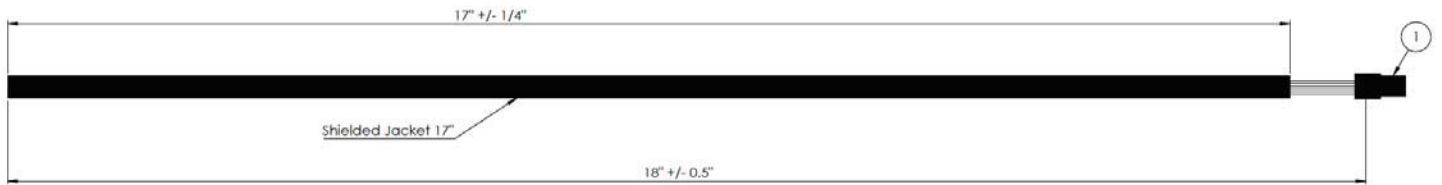

① Matching male and female connector: TE 794617, 794616 or equivalent